

# LP Gas Cushion Tire Lift Trucks

Capacity: 7,000-15,500 lb



## GC35K-GC70K (STR) Series

Designed to increase efficiency, the GC35K-GC70K Series of internal combustion cushion tire lift trucks provides maximum performance in a variety of applications.

### Uncompromising Performance.

This lift truck thrives in applications where its strength can effectively be put to the test. The spacious operator compartment combined with powerful performance results in an operator who is comfortable and productive during long shifts.

### Air Quality.

These rugged trucks provide excellent horsepower and torque while meeting EPA and CARB requirements for carbon monoxide (CO), hydrocarbons (HC) and nitrogen oxide (NOx) emissions.

### Designed For Uptime.

The standard premium LED/LCD display is designed for easy monitoring of truck functions. Extended service intervals, the advanced Engine Protection System and easy access to service components results in increased uptime for your applications.

Model	Capacity (lbs)									
	7,000	8,000	9,000	10,000	11,000	12,000	13,000	14,000	15,000	
GC35K										
GC40K										
GC40K STR										
GC45K SWB										
GC45K STR										
GC55K										
GC55K STR										
GC60K										
GC70K										
GC70K STR										

## Commanding Presence

In control and delivering results. Your Cat® lift truck will help keep your operator comfortable and productive throughout the entire shift.



QUALITY

### Optimized Visibility

Narrow mast channels and open overhead guards help improve operator visibility to the load and surroundings. Standard LED work lights illuminate the work area while providing significant maintenance savings over traditional halogen or incandescent lights.



Increased visibility

### Comfortable Seating

Operators of varying sizes can work long shifts comfortably in the standard full-suspension seat. For high-shuttle applications, an optional reverse drive configuration with swivel seat and a rear grab handle with horn button are also available.



Adjustable seating for increased comfort

### Smart Technology

For added protection, the lift truck comes equipped with a transmission interlock indicator and mast and auxiliary lockout, which helps to protect the operator and surrounding personnel. If the operator is out of the seat, then the transmission is electrically set to neutral and the hydraulic functions are disengaged.



Operator protection

## Step Up In Power

These trucks aren't built to sit on the sidelines. The GC35K-GC70K (STR) Series delivers top performance throughout the shift.



### Options For Applications

Options such as enclosed alternators, torque converter filter and specialty tires can customize the truck for your application's specific needs, while also extending equipment service life and minimizing product damage.



Solutions for your application

### Environmentally-Friendly Engines

The 4.3LV6 engine works in the toughest conditions, while offering excellent fuel economy and low noise and vibration levels.



Increased fuel efficiency, low emissions

### Increased Equipment Protection

The Engine Protection System (EPS) monitors the engine oil pressure, transmission temperature and coolant temperature. The lift truck will slow down or shut off if this system recognizes abnormal conditions.



Protecting your investment

### Serviceability

With 200 hour service intervals, display-based indicators and reminders, and easy access to service components, you can count on maximizing uptime and lowering maintenance costs with your Cat lift truck.

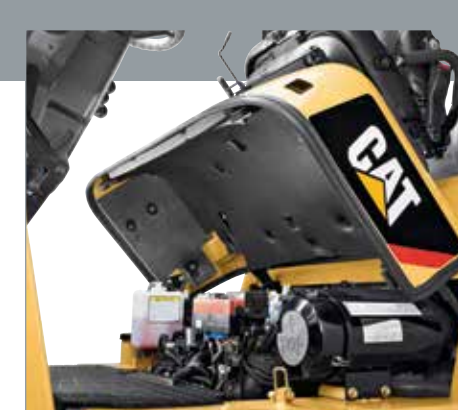

Service time is minimized

## Delivering Real Material Handling Solutions

A Cat lift truck purchase connects you to a variety of material handling solutions, including world-class service and support from the best dealer network in the industry.

Cat Lift Trucks also offers the most comprehensive support programs in the industry. Highly-skilled service technicians, diverse parts inventory and an outstanding selection of service options, all help to reduce your total cost of ownership and keep your lift trucks performing at their best.



### Dealers You Can Depend On

With hundreds of dealer locations throughout North and South America, Cat lift truck dealers provide more than lift trucks. From flexible financing options, to parts, service and product support, our dealers are unsurpassed.



Professionals you can depend on

### Standing Behind Our Products

We deliver peace of mind by helping your trucks stay on the job, day after day. Every new Cat lift truck is covered by a 1-year/2,000 hours warranty that includes parts and labor, as well as components and systems. With our standard 2-year/4,000 hours extended powertrain warranty, you'll have the confidence that only comes from owning a Cat lift truck.



Keeping you covered

### Parts Fast Or Parts Free\*

The Parts Fast Or Parts Free Guarantee ensures next-business-day delivery of all Cat lift truck parts, or they're free, including freight. If your part doesn't come in by the next business day, we pay for it.



Parts when you need them

### Genuine OEM Parts

When you buy from your local dealer, you can be assured that your OEM part is manufactured to meet original equipment criteria. Additionally, all Cat lift truck OEM parts come with a six-month, unlimited-hours warranty.



Genuine Cat Lift Truck OEM parts

### Flexible Financing Options\*

Financing your next Cat lift truck is easy with our wide range of flexible leasing and purchasing options. Whether you want to finance or lease, your local Cat lift truck dealer can help customize a package tailored to your specific needs.



Custom financing packages

\* Programs may be subject to change without notice and may vary by region. Please ask your local Cat lift truck dealer for complete terms and conditions.



Call-out numbers shown in diagram correspond to the first column of the specifications chart.

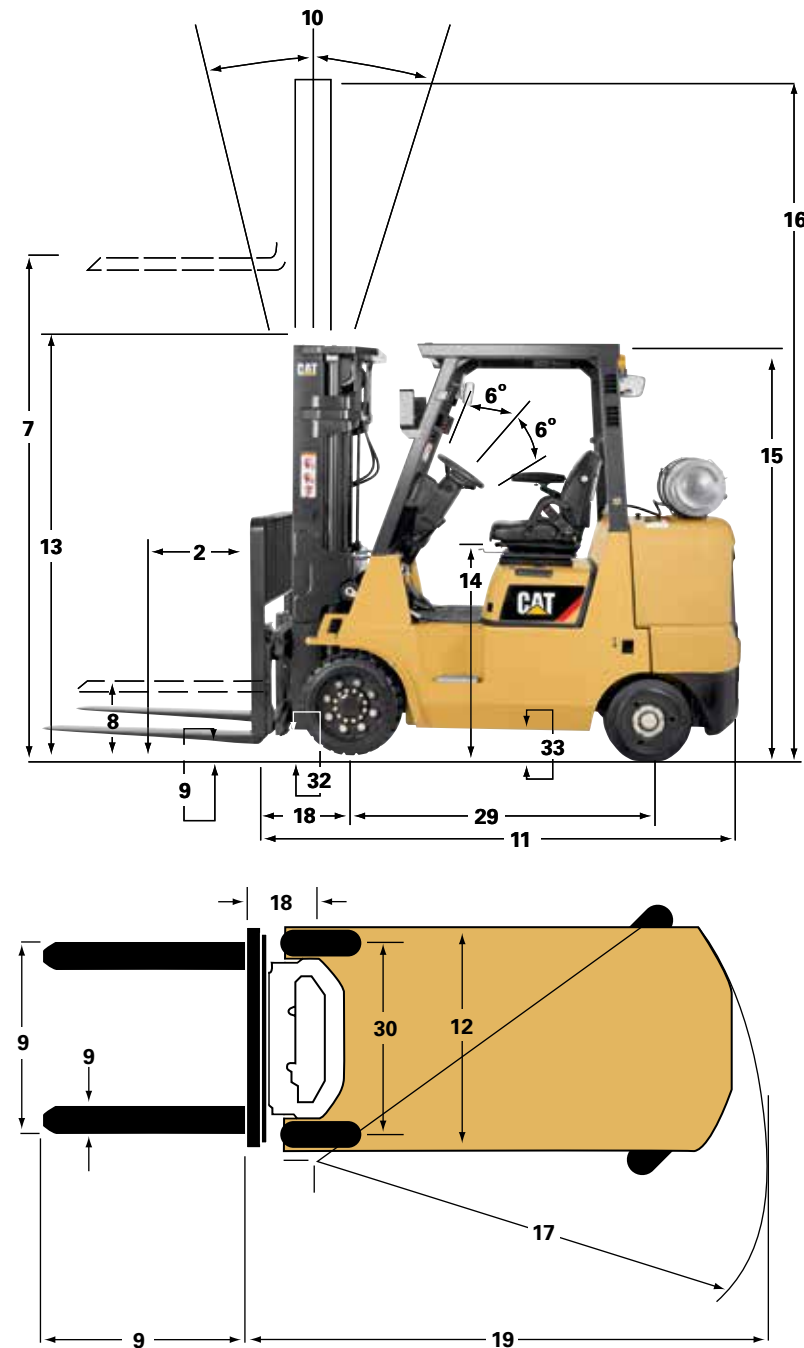

### Safety Standards

These trucks meet American National Standards Institute/ Industrial Truck Standards Development Foundation, ANSI/ITSDF B56.1.

UL-Classified by Underwriters Laboratories, Inc., as to fire and electric shock hazard only. Types LP, LPS (optional), Industrial Trucks. Users should be aware of, and adhere to, applicable codes and regulations regarding operator training, use, operation and maintenance of powered industrial trucks, including:

- ANSI/ITSDF B56.1.
- NFPA 505, fire safety standard for powered industrial trucks - type designations, areas of use, maintenance, and operation.
- Occupational Safety and Health Administration (OSHA) regulations that may apply.

Specifications, equipment, technical data, photos and illustrations based on information at time of printing and subject to change without notice. Some products may be shown with optional equipment.

# ADDITIONAL OPTIONS

### Enhance Your Experience

Cat lift trucks come equipped with features and options that allow you to get the job done. The specialized GC40K-PRH-STR – GC70K-PRH-STR models are equipped with a paper handling chassis and special options designed for the paper product industry. Packaged together, these specialized features provide additional value, helping reduce the need for field modifications.



#### Paper Application Standard Features:

- Hydraulic accumulator
- Hydraulic flow control valve
- Inline row plate fin radiator
- Tandem transmission oil coolers
- Louvered radiator covers
- Carriage slider blocks
- Wrapped exhaust pipes
- Belly screen

Model	Capacity (lbs)								
	7,000	8,000	9,000	10,000	11,000	12,000	13,000	14,000	15,000
GC40K-PRH-STR									
GC45K-PRH-STR									
GC55K-PRH-STR									
GC70K-PRH									
GC70K-PRH-STR									

#### Optional Product Protection:

- 4-position electronic pressure regulator
- Forward tilt lockout for mast
- Drop stop valve in lift circuit
- Flexible fenders





**Quality**

**Reliability**

**Customer Service**

Experienced professionals at your local dealership and on our National Accounts Team can assist you with your lift truck purchase or lease. Your Cat lift truck dealer can provide options and additional visual and audible warning devices geared toward your specific requirements. Operator training programs are also available to boost productivity and to help reduce the potential for product damage and personal injury.



## LP Gas Cushion Tire Lift Trucks

Capacity: 7,000-15,500 lb

**1-800-CAT-LIFT | [www.cat-lift.com](http://www.cat-lift.com) | [m.cat-lift.com](http://m.cat-lift.com)**

Copyright © 2013 by MCFA. All rights reserved. CAT, CATERPILLAR, their respective logos, "Caterpillar Yellow" and the "Power Edge" trade dress, as well as corporate and product identity used herein, are trademarks of Caterpillar and may not be used without permission. All registered trademarks are the property of their respective owners. Some products may be shown with optional equipment. Printed in U.S.A.